

Model GEO-LP02

SECOND CLASS PYRANOMETER



Figure 1 GEO-LP02 Second Class pyranometer

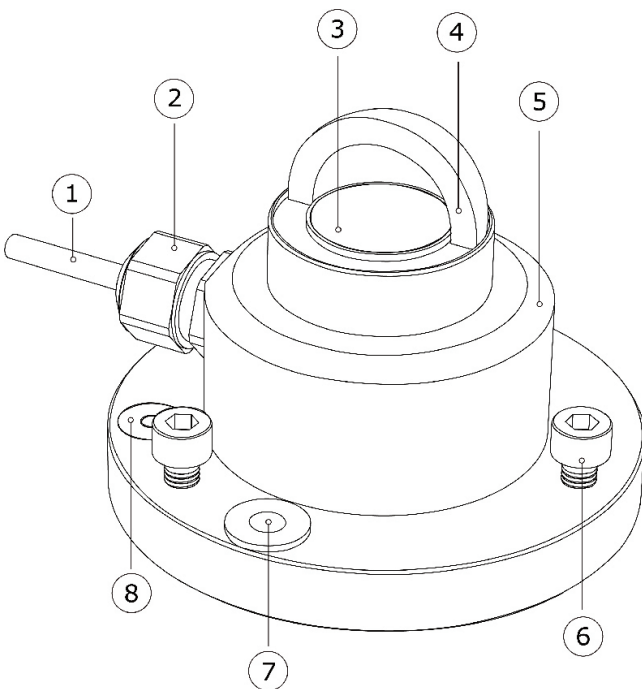

Figure 2 GEO-LP02 overview: (1) cable, (2) cable gland, (3) thermal sensor with black coating, (4) glass dome, (5) sensor body, (6) levelling feet, (7) mounting hole, (8) bubble level

ACCESSORIES

Model SP-101: tilted adjustable (0° to 90°) support. Made 100% from stainless steel with outdoor paint extra protection.

GEO-LP02 is a solar radiation sensor that is applied in most common solar radiation observations. It complies with the Second Class specifications of the ISO 9060 standard and the WMO Guide. **GEO-LP02** pyranometer is widely used in (agro-) meteorological applications and for PV system performance monitoring.

INTRODUCTION

GEO-LP02 is a solar radiation sensor that is applied in general observations. It measures the solar radiation received by a plane surface from a 180° field of view angle. This quantity, expressed in W/m^2 , is called “hemispherical” solar radiation. **GEO-LP02** pyranometer can be employed outdoors under the sun, as well as indoors with lamp-based solar simulators. Its orientation depends on the application and may be horizontal, tilted (for plane of array radiation) or inverted (for reflected radiation). **GEO-LP02** pyranometer is a very good alternative to silicon cell (photodiode-based) pyranometers, which do not comply ISO 9060 standard.

OPERATION

The irradiance in W/m^2 is calculated by dividing the **GEO-LP02** output, a small voltage, by the sensitivity. This sensitivity is provided with **GEO-LP02** on its calibration certificate.

USE AS A SUNSHINE DURATION SENSOR

GEO-LP02 may be used, in combination with appropriate software, to estimate sunshine duration. This is much more cost-effective than using a dedicated sunshine duration sensor. Ask for our application note.

Specifications	
ISO classification	Second class
WMO performance level (WMO-No.8, 7th edition)	Moderate quality
Response time (95%) Response time (63%)	< 18s < 6s
Zero offset a (response to 200 W/m ² net thermal radiation)	< ± 15 W/m ² unventilated
Zero offset b (response to 5 °C/h change in ambient temperature)	< ± 4 W/m ²
Resolution	10 W/m ²
Non-stability	< ± 1% change per year
Non-linearity	< ± 1% (100 to 1000 W/m ²)
Directional response	< ± 25 W/m ²
Spectral selectivity	< ± 5 % (0.35 to 1.5 µm)
Temperature response	< ± 3 % (-10 to +40 °C)
Tilt response	< ± 2 % (0 to 90° at 1000 W/m ²)
Spectral range (50% points)	300 to 2800 nm
Spectral range (20% points)	285 to 3000 nm
Measuring range	0 to 2000 W/m ²
Sensitivity range	7 to 25 µV/(W/m ²)
Sensitivity (nominal)	15 µV/(W/m ²)
Calibration traceability	to WRR
Calibration uncertainty	< 1.8 % (k = 2)
Sensor resistance range	40 to 60 Ω
Field of view	180°
Levelling	bubble level and adjustable leveling feet are included
IP protection class	IP 67

Options

- Additional cable length in multiples of 5 m (add to the standard 5m)

MORE INFORMATION

Datalogger Model **METEODATA-3000C**



METEODATA-3000C
Datalogger/Transmitter Unit
(3G/GPRS, radio or satellite)